

eDynamo Card Reader

635 W. 11th St. | Auburn, IN 46706
www.TempusPayment.com
2021-23-02



Contents

Contents	2
Implementation Guide Overview	3
Requirements	4
Limitations	5
How to turn Device On/Off (Airplane Mode)	6
How To Pair On mPM iOS	7
How To Pair On mPM Android	11
How To Troubleshoot an eDynamo Device	14
Invalid Card Swipes	14
Pairing Issues	14
Device not holding charge	14



Implementation Guide Overview

This document gives details on how to operate the eDynamo card reader. Included are instructions on how to pair to mPaymentMate (mPM) and troubleshoot the device on Android and iOS devices.



Requirements

To set up the eDynamo card reader, the following items are required:

- A RNID that is capable of running transactions through the mPaymentMate app
- An eDynamo card reader
- An Android or iOS device that has the mPaymentMate

i Note: There are no extra configurations that need to be set for the ability to use an eDynamo card reader.



Limitations

- Minimum Gateway version: 2.1.1027.1000
- Minimum mPaymentMate (mPM) iOS version: 2.10.1
- Minimum mPaymentMate (mPM) Android version: 2.10.1



How to turn Device On/Off (Airplane Mode)

In its default configuration, the device's Bluetooth LE module can be toggled between advertising and not advertising to save power or to stop radio emissions for airline travel. This state is known as Airplane Mode, and can also be considered the device's "Off" state. Operators can toggle Airplane Mode as follows:

- To Turn Airplane Mode On: If the device is advertising, press and hold the power button for 5 to 10 seconds to reset the Bluetooth LE module and turn advertising off. The device also resets to this state if the battery completely discharges.
- To Turn Airplane Mode Off: If the device is not advertising, briefly press and release the power button or connect the device to USB power to turn advertising on.

How To Pair On mPM iOS

1. Launch the mPM iOS app.
2. Select the **Configure** option.

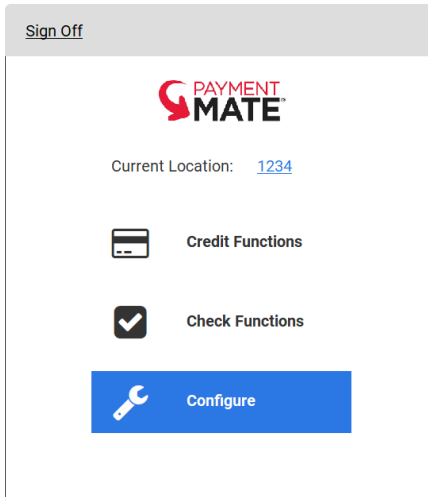

3. On the *Configure* screen click **Card Reader**.

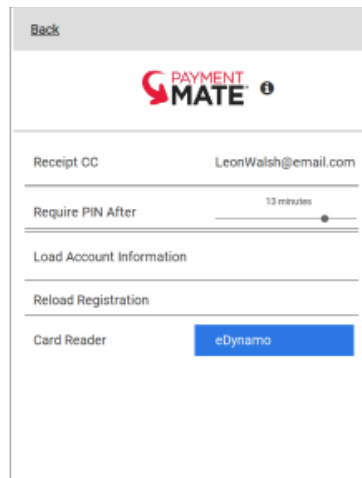

4. Select **Back** to return to the home screen

5. Select **Credit Functions**

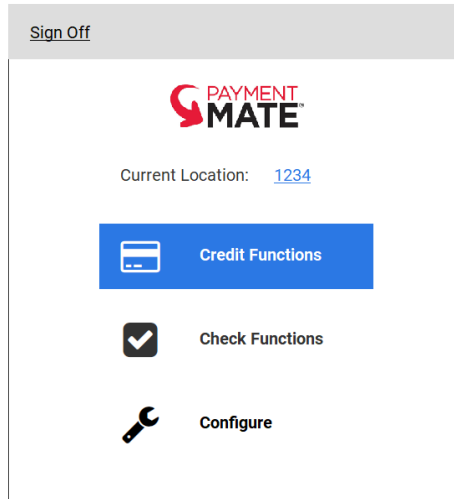

6. To start pairing, hold the button on the side of the eDynamo device until it flashes three times. Then the light will flash blue every second.

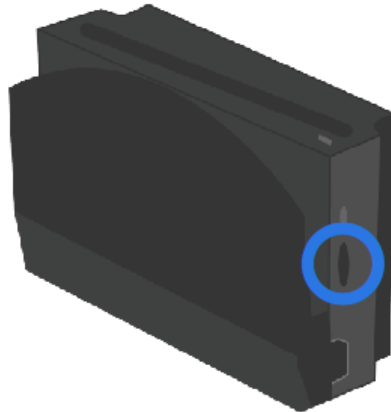

7. Select an account to start pairing.

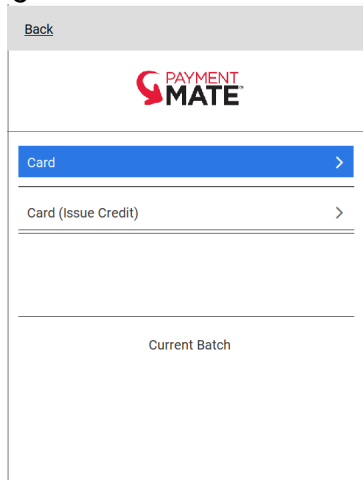

8. Enter the pair code for the eDynamo card reader in the modal. The default code is 000000.

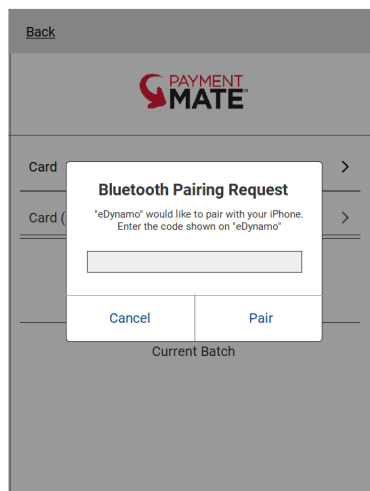



9. The eDynamo card reader is now connected to the iOS device and is ready to accept payments.

Back Process Clear	
Amount \$	5.00
Card Number	0000000000000000
Expiration Date	01/01
CVV	111
AVS (Zip Code)	
Tran Ident	
Card Name	

Waiting for card



10. Test the connection with a transactions.

How To Pair On mPM Android

1. Open the Android settings app and click **Bluetooth**.
2. To start pairing, hold the button on the side of the eDynamo device until it flashes three times. Then the light will flash blue every second.

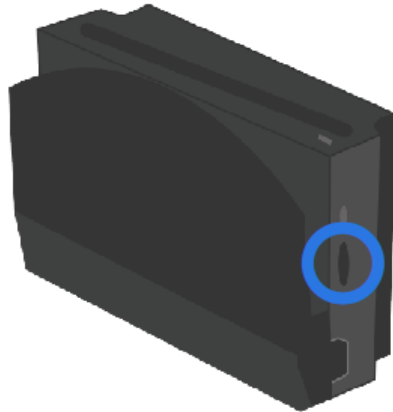

3. Find the eDynamo device from the list of available devices and then connect to the device that matches the name of that device.
4. Enter the pair code for the eDynamo card reader in the modal. The default code is 000000.

Bluetooth pairing request

eDynamo

Enter PIN to pair the device

e.g. 0000 or 1234

Use QWERTY Keyboard

CANCEL PAIR

5. The eDynamo card reader is now connected to the Android Device.
6. Launch the mPM Android app.

7. Select the **Configure** option.

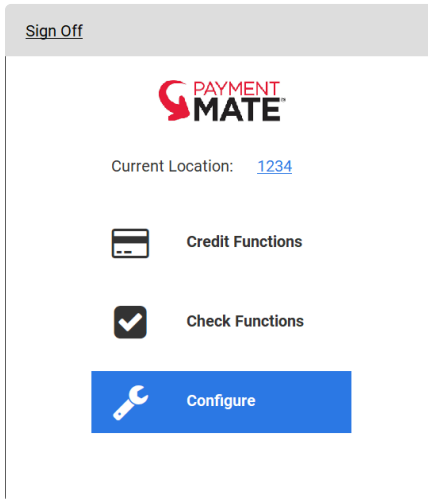

8. On the *Configure* screen click **Card Reader**.

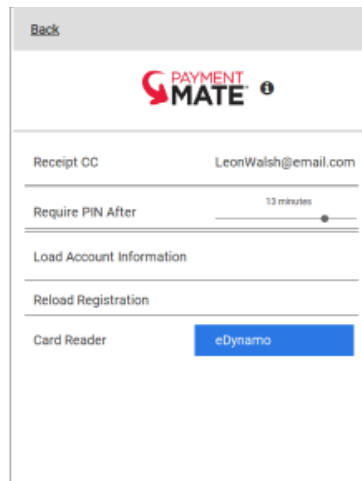

9. Select **Back** to return to the home screen

10. Select **Credit Functions**

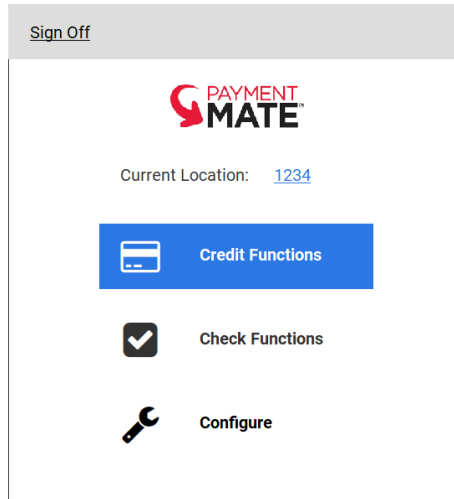

11. The eDynamo card reader will automatically connect to the Android device when a Service Name is selected and is ready to accept payments.

Back Process Clear	
Amount \$	5.00
Card Number	0000000000000000
Expiration Date	01/01
CVV	111
AVS (Zip Code)	
Tran Ident	
Card Name	
<div style="display: flex; justify-content: space-between; align-items: center;"> Waiting for card  </div>	

12. Test the connection with a transaction.

How To Troubleshoot an eDynamo Device

This document will help troubleshoot eDynamo card reader issues around invalid card swipes and issues with pairing the device to Android or iOS device.

ⓘ Note: Most issues can be solved by refreshing the app. The eDynamo card reader does not have a charge level indicator and does not turn off on its own unless the battery is dead. Always make sure the eDynamo card reader is charged.

Invalid Card Swipes

- Swipe the card using the eDynamo card reader

Pairing Issues

- If the eDynamo card reader does not show in the available devices list on an Android device, close the app and try
- If the eDynamo card reader was previously connected to a different device by the user, use the “Forget Device” feature and try pairing
- If multiple eDynamo card readers are paired to a single Android or iOS device, use the “Forget Device” feature to remove the other card readers and try pairing again.

Device not holding charge

- Turn on Airplane Mode, which is considered the device’s “Off” state.
 - To Turn Airplane Mode On: If the device is advertising, press and hold the power button for 5 to 10 seconds to reset the Bluetooth LE module and turn advertising off. The device also resets to this state if the battery completely discharges.



- To Turn Airplane Mode Off: If the device is not advertising, briefly press and release the power button or connect the device to USB power to turn advertising on.